

GRADE 5, 1/2-20  
 NYLOCK HEX NUT  
 (3) REQUIRED

GRADE 5, 1/2" FW  
 (1) REQUIRED

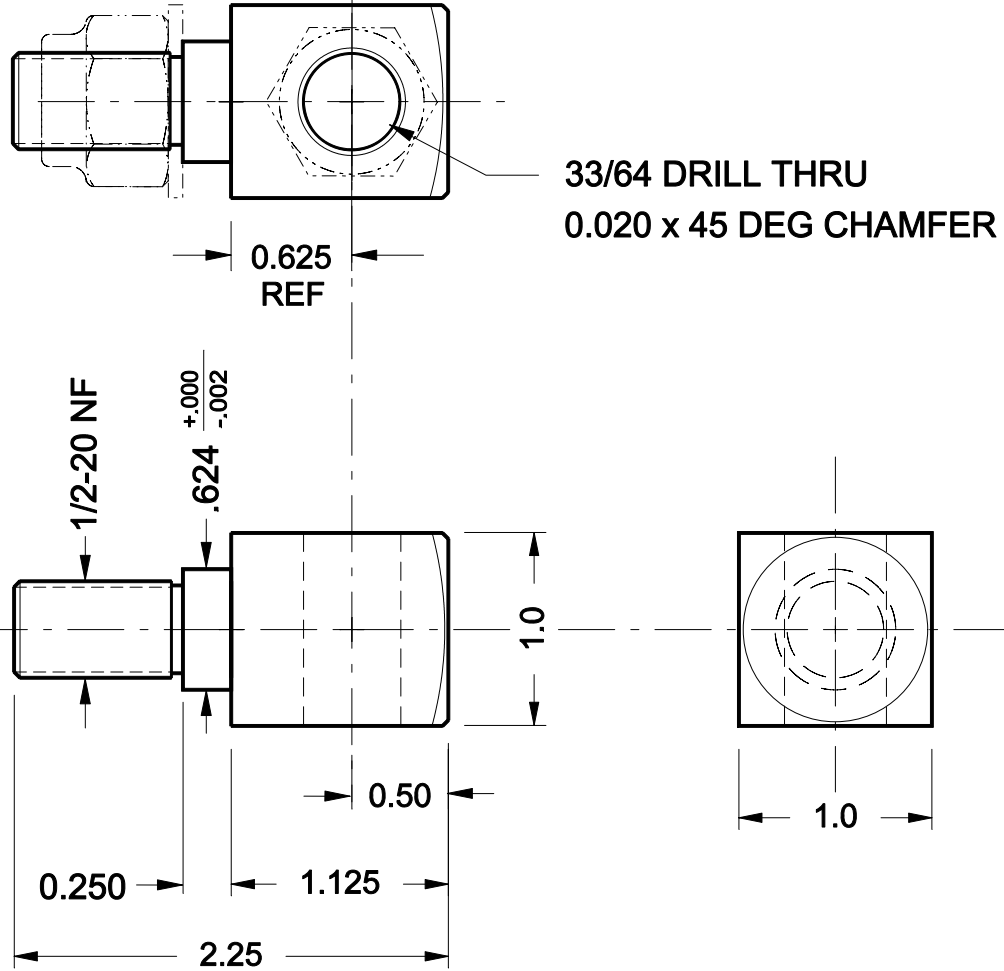

MATERIAL : MILD STEEL, 1050 OR 4140

HEAT TREAT : N/A

FINISH : RMS 125 OR BETTER

QUANTITY : 1

DEBURR OR ROUND ALL SHARP CORNERS

ALL DIMENSIONS IN INCHES

DECIMAL DIMENSIONS +/- .005" FRACTIONS +/- 1/64 EXCEPT AS NOTED

# DEMPSEY'S FORGE

DATE

TITLE

10-19-2010

**X-1 TIE-ROD CONECTOR**

SCALE

Copyright © 2010 Jock Dempsey, anvilfire.com

NTS

N° : X - 001 - 0 - ?